



*Geology, Prospectors, Mining, Metallurgy,
Assaying, Environmental, Geotechnical*

988 Packer Way
Sparks, NV 89431
Tel: (786) 786-3003
Fax: (775) 786-3613
Email: info@Lmine.com
Web: www.Lmine.com

BICO CHIPMUNK JAW CRUSHER - TYPE WD

The Bico Chipmunk Jaw Crusher is designed to give long and efficient service. In order to secure the long life and excellent performance that your crusher is capable of delivering it is essential that the following directions for operation and maintenance be carefully observed.

THE MECHANICS OF ITS SUCCESSFUL DESIGN

The upper end of the jaw travels in a circular path driven by the eccentric shaft. The lower end oscillates through a short arc described by the toggle. The resultant jaw action is forward and downward motion relative to the stationary jaw that crushes the sample and forces its discharge. The discharge opening between jaws can be adjusted to control crushed particle size by turning the hand wheel on the side of the crusher. The adjusting mechanism consists of steel wedge blocks operated by a screw. The wedge blocks transmit crushing forces from the jaw to the frame, relieving all strain on the adjusting screw itself. The stationary jaw is simply lifted out of the frame to completely expose the inner parts for thorough brushing and cleaning. Dropping the cam-lock handle anchors the jaws securely in position. Jaw plates are tough, thick steel and are reversible end for end for double wear. Heavy bronze bearings are sealed against dust and dirt and are lubricated by grease cups so that no special greasing tools are required.

INSTRUCTIONS

The Flat Faced Pulleys on the VD and WD Crushers as run with V-Belts is a specially engineered arrangement for these machines. This combination has been in use for many years in the manufacture of this crushing equipment and has proven to be the very best arrangement for machines such as these. When equipment is confronted with a "SHOCK LOAD" condition, this vbelt/ flat pulley arrangement allows just enough "give", thus preventing undue strain on the key, flywheel and eccentric shaft. Manganese Steel plates are available on special order. It is recommended that only one plate, preferably the Stationary plate, be of this material. Two Manganese Steel plates will not reduce hard ores satisfactorily because there is insufficient "grab" between the surfaces. Manganese plates are wear hardened with impact and heating.

INSTALLATION

Unpack your Crusher and set it on a platform in the desired location. Insert the mounting blocks under each side of Crusher to raise the unit and allow clearance for the ore pan. Securely bolt to platform. Check the alignment of v-belts from the grooved motor pulley to the flat-faced pulley. This alignment is critical as it is only the alignment that keeps the belts on the Flat-faced Drive Pulley. **ROTATION IS CLOCKWISE WHEN FACING THE DRIVE PULLEY.** Connect the relay switch to your power source in accordance with the directions enclosed with the switch. Just above the junction box on the motor is a direction plate indicating the proper wiring for your current. Connect the Crusher to the relay switch in accordance with these directions. **AGAIN, ROTATION IS CLOCKWISE WHEN FACING THE DRIVE PULLEY.** The magnetic starting switch has internal overload protection. This shuts off the current automatically should the Pulverizer jam through improper adjustment of the plates or the introduction of foreign matter into the grinding chamber. Should an overload occur, wait a few minutes to permit the relay to cool and then press the RESET button. The jaws are preset at the factory to a gap of 1/32". Before starting the crusher for the first time, the gap should be checked to see that this space has not been altered in shipping or setting up the machine. A tighter gap could result in damage to the machine. The crusher can be adjusted by loosening the jam nut and setscrew on the left hand side and turning the adjusting screw on the right side of the machine. Turning the flywheel located at the right side of the machine to the left or right will open or close the space between the lower parts of the jaw so as to give the required crushing size. **DO NOT SET THE JAWS**

TIGHTLY TOGETHER as this will result in damage to the machine (minimum allowable opening is 1/32 inch on forward stroke of movable jaw).

ADJUSTMENTS

Heavy bronze bearings are sealed against dust and dirt, and are lubricated by grease cups so that no special greasing tools are required. To tighten the bearings, loosen the two square headset screws (behind the cap) a fraction. Turn the four hex-head bolts down a fraction at a time. Check tightness by turning the pulley or flywheel by hand. There should be a very slight drag. To loosen, reverse the procedure. Bolts must be tight, but not too tight. **USE EXTREME CAUTION AS OVER-TIGHTENING THE SQUARE OR HEX HEAD SCREWS WILL BREAK THE CAPS.** The caps will radiate some heat, which is normal. Bearings should not be run loose or excessive wear will result on the bearing, shaft, etc. Check the bolts on a regular basis, as the machines vibration will have a tendency to loosen the various bolts.

MAINTENANCE

It is of the greatest importance that the crusher is kept properly lubricated at all times (use any good quality hi-temperature grease. We use a lithium-based grease). Turn down the grease cups 1/4 of a turn at least once a day, or more if the machine is in constant use. This will protect the bearings. Oil the adjusting blocks and toggle block approximately once a week. An oil cup is provided for this purpose at the front of the spacer casting and at the rear toggle block. When the plates are worn to a point where readjustment is necessary, they can be adjusted. To do this simply insert the set of shims provided with each crusher between the jaw and jaw plate. This will compensate for wear. For still further adjustment, and for resetting the adjusting blocks, loosen the small setscrew at the left side of the crusher. Turn hand wheel to the right, which will allow the adjusting block to move forward.

RECOMMENDED SPARE PARTS FOR NORMAL ONE (1) YEAR OPERATION FOR WD CRUSHER

2 ea.	WD-60	Toggle
2 ea.	WD-65A	Right Hand Bearing Split Bushing
2 ea.	WD-65B	Left Hand Bearing Split Bushing
2 ea.	WD-74	Plate for Stationary Jaw
2 ea.	WD-74A	Plate for Stationary Jaw/Manganese
1 ea.	WD-76	Adjusting Screw
2 ea.	WD-77	Cheek Plate
2 ea.	WD-78	Plate for Movable Jaw
2 ea.	WD-78A	Plate for Movable Jaw/Manganese
2 ea.	WD-79	Spring Rod w/Wing Nut
2 ea.	WD-80	Spring
1 ea.	WD-132	V-Belts, matched set of 4

BICO INC. WD CRUSHER SPARE PARTS LIST

CATALOG # DESCRIPTION LBS/KG (PLEASE ADVISE SERIAL NUMBER WHEN ORDERING SPARE PARTS)

WD-55	Movable Jaw Complete with Cap, Bushing, 40/18 Jaw Plate and U-Hook
WD-56	Front Spacer 40/18
WD-57	Adjusting Block complete with Wedge Block, 15/7Swivel Block, Pen and Key
WD-57A	Adjusting Block with Swivel Block 9/4
WD-57B	Adjusting Wedge Block with Key 6/3
WD-57C	Swivel Block Pin 1/4
WD-57X	Adjusting Block Modified for 1" Opening 13/6(Cleaver)
WD-58	Swivel Block (Sold only with Adjusting Block) 5/2
WD-59	Movable Jaw Cap 3/1
WD-60	Toggle 3/1
WD-61	Toggle Block 10/5
WD-62	Left Hand Bearing Cap 6/3

WD-63	Right Hand Bearing Cap 6/3
WD-64	Bearing Casting Complete with Caps and 40/18 Bushing
WD-65A	Right Hand Bearing Split Bushing 3/1
WD-65B	Left Hand Bearing Split Bushing 3/1
WD-66	Movable Jaw Split Bushing 3/1
WD-67	Right Hand Frame Plate 35/16
WD-68	Left Hand Frame Plate 35/16
WD-69	Shaft for Single Pulley for V-Belt Drive (short) 12/6
WD-70	Shaft for Tight & Loose Pulley (Long) 16/7
WD-71	Shaft Collar 1/4
WD-72	Stationary Jaw Complete with Plate, Handle 30/14 and Jaw Pin
WD-72A	Stationary Jaw Pin 1/4
WD-72X	Stationary Jaw Complete for 1" Modified 28/13 opening (Clever)
WD-73	Frame Stud for Stationary Jaw 1/4
WD-74	Stationary Jaw Plate-Regular Steel 6/3
WD-74A	Stationary Jaw Plate-Manganese Steel 6/3
WD-74SS	Stationary Jaw Plate-Stainless Steel 6/3
WD-75	Handle for Stationary Jaw 3/1
WD-76	Adjusting Screw 1/4
WD-76A	Hand Wheel for Adjusting Screw 1/4
WD-77	Cheek Plate 4/2
WD-77SS	Cheek Plate-Stainless Steel 4/2
WD-78	Movable Jaw Plate-Regular Steel 6/3
WD-78A	Movable Jaw Plate-Manganese Steel 6/3
WD-78SS	Movable Jaw Plate-Stainless Steel 6/3
WD-79	Spring Rod with Wing Nut 1/4
WD-80	Spring 1/4
WD-81	Ore Pan 2/1
WD-82	Mounting Block-Plain 10/5
WD-82R	Mounting Block-Adjustable-Right Hand 13/6
WD-82L	Mounting Block-Adjustable Left Hand 13/6
WD-83	Flywheel 44/20
WD-84	Tight Pulley-Crowned for Flat-Belt Drive 43/20
WD-85	Loose Pulley-Crowned for Flat-Belt Drive 43/20
WD-88	Grease Cup 1/4
WD-89	Oil Cup for Front Spacer and Toggle Block 1/4
WD-90	Key for Shaft-Long or Short Shaft 1/4
WD-110	Key for Adjusting Block 1/4
WD-111	Dust Plate 1/4
WD-112	Dust Cover Plate 1/4
WD-113	Shims-16 Gauge (Set of 2) 1/4
WD-114	Collar for Adjusting Screw 1/4
WD-115	Upper Felt Gasket - 5" - Set of 2 1/4
WD-116	Lower Felt Gasket - 4 1/4" - Set of 2 1/4
WD-117	Spring Cup - Front or Rear 1/4
WD-118	Hand Wheel for Spring Rod 1/4
WD-119	Pipe Spacer for Frame Stud 1/4
WD-120	Fiber Dust Washer for Pulley and Flywheel 1/4
WD-121	Cap Screw for Front Spacer 1/4
WD-122	Cap Screw for Movable Jaw 1/4
WD-123	Cap Screw for Toggle Block 1/4
WD-124	Cap Screw for Left Hand Bearing Cap 1/.4
WD-125	Cap Screw for Right Hand Bearing Cap 1/.4
WD-126	Bolt for Movable Jaw Plate 1/.4
WD-127	Bolt for Bearing Casting 1/.4
WD-128	Bolt for Stationary Jaw Plate 1/.4
WD-129	Bolt for Cheek Plate 1/.4

WD-130	Pulley-Special Flat-Faced for V-Belt Drive 37/17
WD-131	4-Groove Pulley for motor (Specify RPM, 8/4Keyway and Shaft Diameter)
WD-132	V-Belts (Set of 4) 1/4
WD-133	U-Hook Bolt for Spring Rod for Movable Jaw 1/4
WD-136	Adjusting Screws for Mounting Block 1/4
WD-140	Belt Guard, Old Style 60/27
WD-145	Flywheel Guard, Old Style 60/27
WD-146	Hopper 37/17
WD-148	Belt Guard, New Style 60/27
WD-149	Flywheel Guard, New Style 60/27

ADJUSTING THE CHIPMUNK JAW CRUSHER

Note: Steps 1 & 2 only need be completed if attempting to close the jaw gap beyond the factory setting, as when closing the gap to compensate for wear on the grinding plates.

1. Loosen the hex head jam nut, which is the nut against the crusher body (fig. 1)
2. Loosen the square head set screw. (fig. 2)
3. Turn the hand wheel (fig. 3) to the right to close/increase the jaw gap, or to the left to open/increase it. When the desired opening has been set reverse steps one and two.

NOTE: DO NOT SET JAWS TIGHTLY TOGETHER as this will result in damage to the machine. Minimum allowable gap is 1/32 inches on the forward stroke of movable jaw.

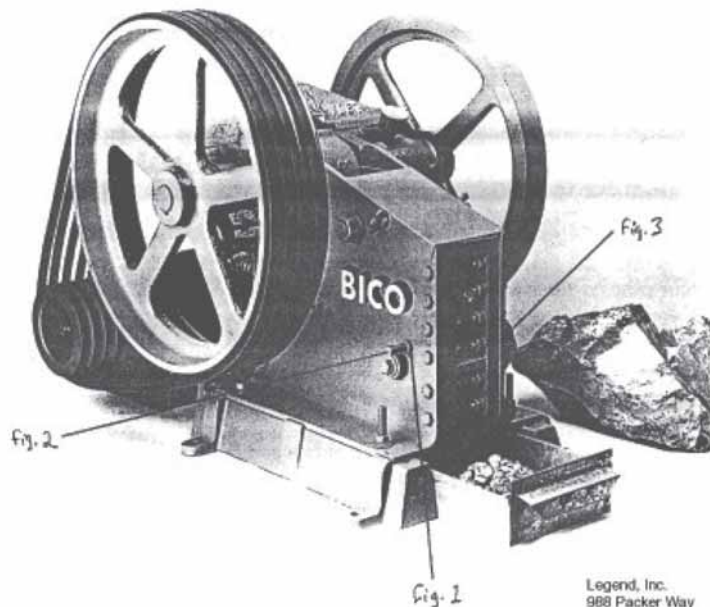

Legend, Inc.
988 Packer Way
Sparks, NV 89431 USA
ph: (775) 786-3003
fax: (775) 786-3613
info@lmine.com

ADJUSTING THE CHIPMUNK JAW CRUSHER

Note: Steps 1 & 2 only need be completed if attempting to *close* the jaw gap beyond the factory setting, as when closing the gap to compensate for wear on the grinding plates.

1. Loosen the hex head jam nut, which is the nut against the crusher body (fig. 1)
2. Loosen the square head set screw. (fig. 2)
3. Turn the hand wheel (fig. 3) to the right to close/increase the jaw gap, or to the left to open/increase it. When the desired opening has been set reverse steps one and two.

NOTE: DO NOT SET JAWS TIGHTLY TOGETHER as this will result in damage to the machine. Minimum allowable gap is 1/32 inches on the forward stroke of movable jaw.

PROCEDURE TO REPLACE PARTS ON THE WD CHIPMUNK CRUSHER

(FOLLOW NUMBERED PROCEDURES)

1. REMOVE HOPPER & ORE PAN
2. REMOVE GUARDS & BELTS
3. REMOVE WD-112. 4. PRY UP WD-75 AND LIFT OUT WD-75 & WD-72
5. REMOVE PULLEY & FLYWHEEL
6. REMOVE GREASE CUPS
7. REMOVE 8 BEARING CAP BOLTS AND REMOVE BOTH BEARING CAPS

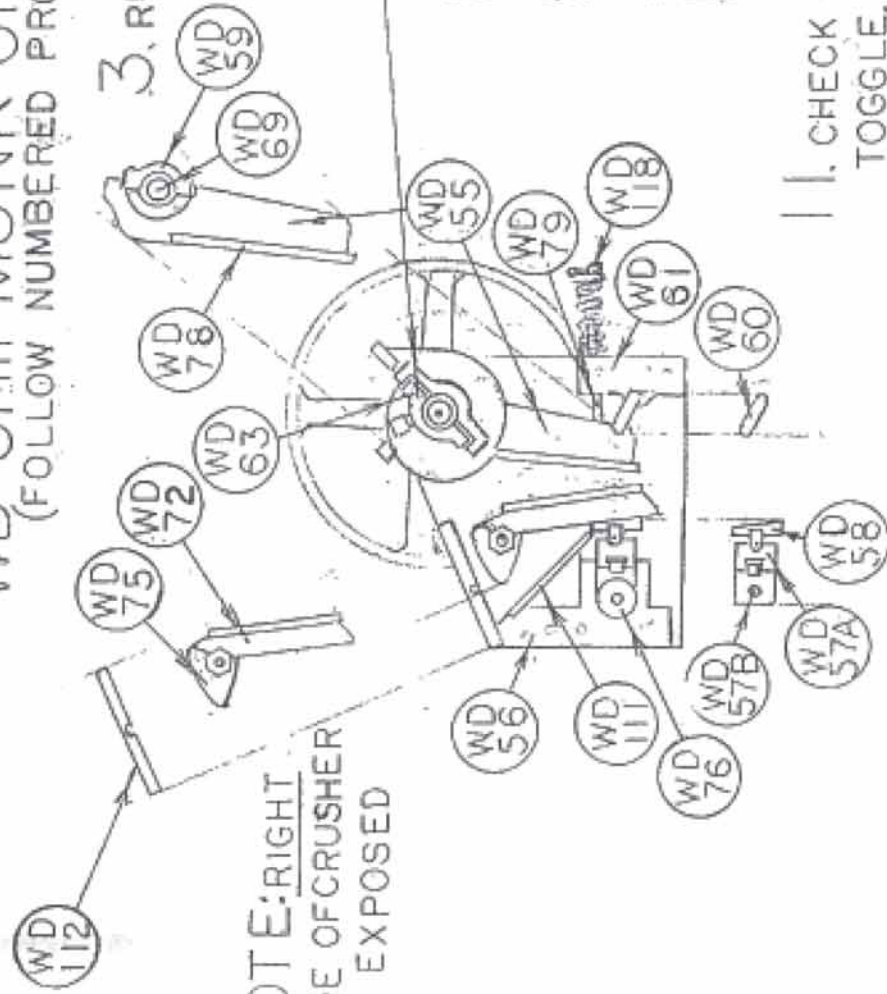

NOTE: RIGHT
SIDE OF CRUSHER
EXPOSED

8. UNHOOK WD79 & LIFT OUT WD-69 & WD-55 (WD-60 WILL DROP OUT)
9. REMOVE WD-111 & WD-76 & SLIDE OUT WD-57B, WD-57A & WD-58
10. REMOVE WD-59

11. CHECK ALL PARTS FOR WEAR (TOGGLE BLOCK, TOGGLE, ALL BUSHINGS, JAW & CHEEK PLATES, ETC.)

NOTE: TO REMOVE WD 57-B, WD-57A & WD-58 ONLY: (A) REMOVE WD-112. (B) PRY UP WD-75 AND LIFT OUT WD-75 & WD-72. (C) REMOVE WD-78 & BOTH CHEEK PLATES. (D) LOOSEN WD-118 & UNHOOK WD-79 & REMOVE WD-60. (E) REACH UNDER CRUSHER & REMOVE WD-57B, WD-57A & WD-58

ASSEMBLY HINTS: NEVER OVERTIGHTEN ANY BEARING BOLT OR SET JAWS. (CAUSE DAMAGE)

1. ASSEMBLE IN REVERSE ORDER TO #3-11
2. DRIVE (BELT) PULLEY GOES WITH WD-62
3. TO REPLACE WD-57B, WD-57A & WD-58 ONLY: FOLLOW ON LEFT SIDE OF CRUSHER (OPP. WD-76) (A) TO (F) IN REVERSE. 4. TO ADJUST BEARINGS: LOOSEN THE SQUARE HEAD SET SCREWS (BEHIND THE CAPS); TIGHTEN THE HEX HEAD BOLTS A FRACTION AT A TIME, ALTERNATELY AND EVENLY. (THE RIGHT TIGHTNESS IS WHEN A VERY SLIGHT DRAG IS FELT WHEN PULLEY OR FLYWHEEL IS TURNED BY HAND) SNUG UP SQUARE HEAD SET SCREWS

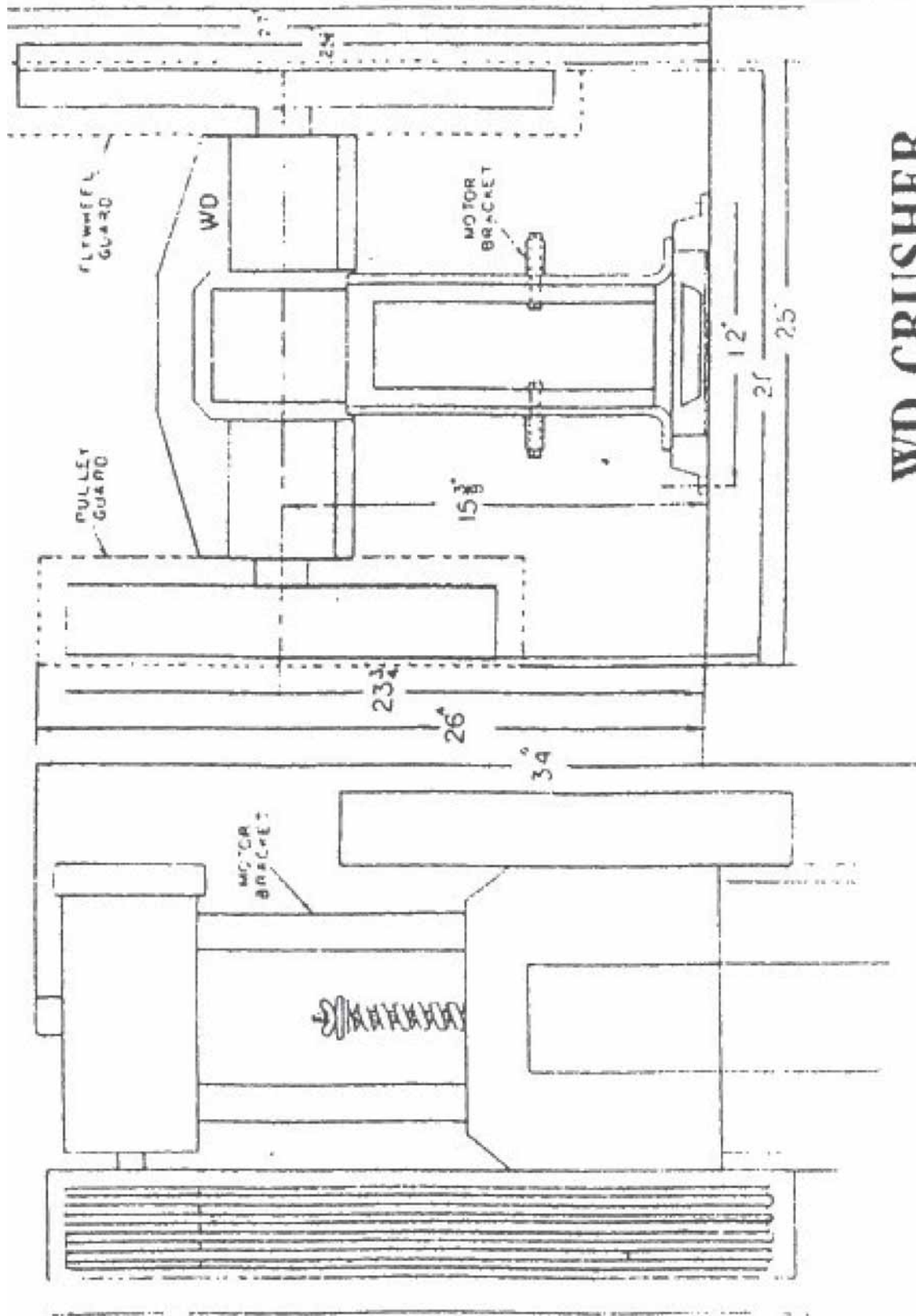

WD CRUSHER